

ROLLER REAMERS

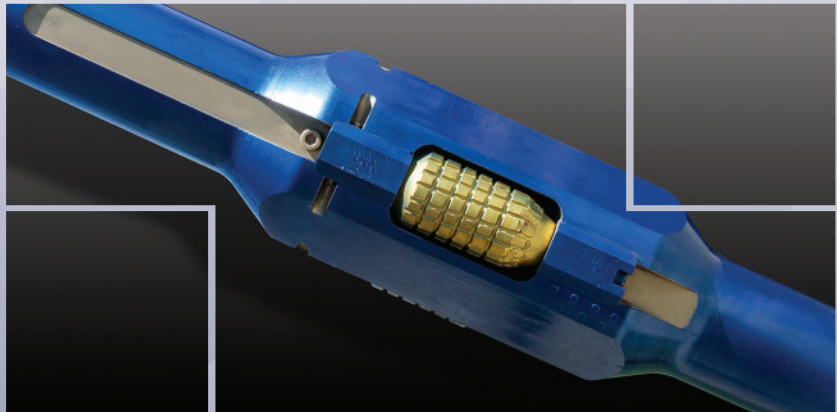

Drilling Tools International manufactures, sells, and rents roller reamers in three-point and six-point configurations. Another versatile downhole drilling component, roller reamers complement Drilling Tools' broad range of downhole stabilization products. They can be used in straight and directional drilling applications when a side wall cutting action is necessary and/or for point stabilization near the bit or further up in the drill string.

Drilling Tools' roller reamers make the difference downhole when used to maintain hole gauge, wipe out key seats, and smooth out rough and troublesome ledges which will cause the drill stem to stick and bind. These roller reamers also help to reduce drill stem torque in highly deviated (horizontal) boreholes and can greatly assist the operator in maintaining drill stem stability.

You have the flexibility to use the style that suits your drilling needs best and provides you with the maximum reaming and side wall cutting action. Combining three-point or six-point stabilization with reaming keeps the hole to size, the bit on track, and ensures smoother drilling operations.

- Available in soft, medium, hard, and smooth
- Available in three-point and six-point configurations
- Cutters can easily be replaced on rig floor

Heat treated and machined with precise dimensional control, Drilling Tools' roller reamer parts are inspected in the pre- and post-manufacturing process phases and checked again for conformance to interchangeability needs and requirements.

SEALED BEARING ROLLER REAMER

The improved reliability of a sealed bearing cutter and compression fit blocks has helped mitigate the effects of side load impacts and effectively withstands the high rates of rotation placed on the reamer during drilling. Adding the seals to the cutter has allowed us to meet customers performance expectations and provide a value competitive product in the high-performance reamer market.

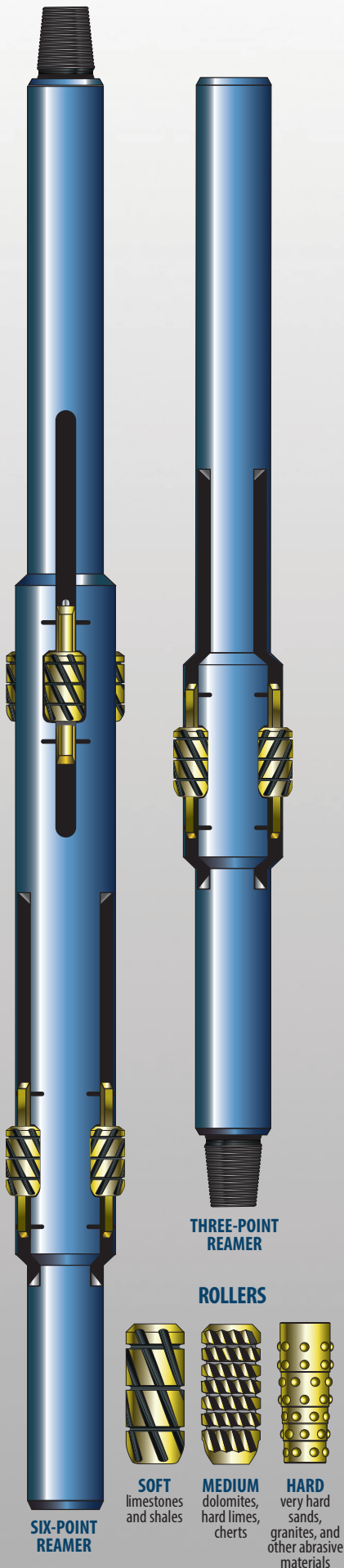

THREE-POINT
REAMER

ROLLERS



SOFT
limestones
and shales

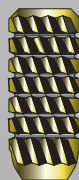

MEDIUM
dolomites,
hard limes,
cherts

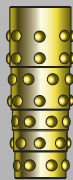

HARD
very hard
sands,
granites, and
other abrasive
materials

SIX-POINT
REAMER

ROLLER REAMERS

SPECIFICATIONS

Hole Size (in)	Roller Reamer Series	Upset Diameter (in)	Maximum Fishing Neck Diameter (in)	Maximum Inside Diameter (in)	Overall Length		Block Size	Bearing Pin Size (in)	Cross Pin Size OD x Length	Cutter Size (in)	Secondary Locking Bolt OD x Length	Assembly Weight	
					3PT (lbs)	6PT (lbs)						3PT (lbs)	6PT (lbs)
4 1/8"	R3750	3.75"	3 1/2"	1.000"	48	74	3/4A	3/4"	1/4" x 1 3/4"	1 3/8"	N/A	150	200
4 5/8"	R4250	4.25"	4"	1.000"	48	74	7/8A	7/8"	1/4" x 1 3/4"	1 1/2"	N/A	300	400
4 3/4"	R4250	4.25"	4"	1.000"	48	74	7/8B	7/8"	1/4" x 1 3/4"	1 1/2"	N/A	300	400
5 5/8"	R5000	5.00"	4 1/2"	1.000"	79	114	1A	1"	5/16" x 2"	2"	N/A	350	600
5 7/8"	R5000	5.00"	4 1/2"	1.000"	79	114	1C	1"	5/16" x 2"	2"	N/A	350	600
6"	R5500	5.50"	5"	1.250"	79	114	1A	1"	5/16" x 2"	2"	1/2" x 1/2"	425	700
6 1/8"	R5500	5.50"	5"	1.250"	79	114	1B	1"	5/16" x 2"	2"	1/2" x 1/2"	425	700
6 1/4"	R5500	5.50"	5"	1.250"	79	114	1C	1"	5/16" x 2"	2"	1/2" x 1/2"	425	700
6 1/2"	R5501	5.50"	5"	1.875"	79	114	1C	1"	5/16" x 2"	2"	N/A	425	700
6 5/8"	R5501	5.50"	5"	1.875"	79	114	1D	1"	5/16" x 2"	2"	N/A	425	700
6 3/4"	R5501	5.50"	5"	1.875"	79	114	1E	1"	5/16" x 2"	2"	N/A	425	700
7 5/8"	R7001	7.00"	6 1/4"	2.250"	79	114	1 1/8A	1 1/8"	1/2" x 2 1/2"	2 1/4"	1/2" x 1/2"	750	1200
7 7/8"	R7001	7.00"	6 1/2"	2.250"	79	114	1 1/8C	1 1/8"	1/2" x 2 1/2"	2 1/4"	1/2" x 1/2"	750	1200
8 3/8"	R7751	7.75"	6 3/4"	2.250"	82	124	1 3/8A	1 3/8"	1/2" x 2 1/2"	2 5/8"	1/2" x 1/2"	950	1500
8 1/2"	R7751	7.75"	6 3/4"	2.250"	82	124	1 3/8B	1 3/8"	1/2" x 2 1/2"	2 5/8"	1/2" x 1/2"	950	1500
8 5/8"	R7751	7.75"	6 3/4"	2.250"	82	124	1 3/8B	1 3/8"	1/2" x 2 1/2"	2 3/4"	1/2" x 1/2"	950	1500
8 3/4"	R7751	7.75"	6 3/4"	2.250"	82	124	1 3/8C	1 3/8"	1/2" x 2 1/2"	2 3/4"	1/2" x 1/2"	950	1500
9 1/2"	R8750	8.75"	8"	2.250"	84	129	1 3/4A	1 3/4"	1/2" x 3"	3 1/8"	1/2" x 3/4"	1250	2000
9 5/8"	R8750	8.75"	8"	2.250"	84	129	1 3/4B	1 3/4"	1/2" x 3"	3 1/8"	1/2" x 3/4"	1250	2000
9 7/8"	R8750	8.75"	8"	2.250"	84	129	1 3/4D	1 3/4"	1/2" x 3"	3 1/8"	1/2" x 3/4"	1250	2000
10 5/8"	R9500	9.50"	8"	2.250"	84	129	1 3/4A	1 3/4"	1/2" x 3"	3 1/4"	1/2" x 3/4"	1300	2200
11"	R9500	9.50"	8"	2.250"	84	129	1 3/4D	1 3/4"	1/2" x 3"	3 1/4"	1/2" x 3/4"	1300	2200
12"	R10500	10.50"	10"	2.812"	89	140	2 1/4C	2 1/4"	1/2" x 3 3/4"	4"	3/4" x 3/4"	2000	3300
12 1/4"	R10500	10.50"	10"	2.812"	89	140	2 1/4E	2 1/4"	1/2" x 3 3/4"	4"	3/4" x 3/4"	2000	3300
13 3/4"	R11750	11.75"	10"	2.812"	89	140	2 1/4E	2 1/4"	1/2" x 3 3/4"	4"	3/4" x 3/4"	2200	3700
14 3/4"	R12750	12.75"	10"	2.812"	93	148	2 1/2A	2 1/2"	7/8" x 4 3/4"	5 1/2"	1" x 1"	2400	4400
15"	R12750	12.75"	10"	2.812"	93	148	2 1/2C	2 1/2"	7/8" x 4 3/4"	5 1/2"	1" x 1"	2400	4400
17 1/2"	R15000	15.00"	11"	3.000"	93	148	2 1/2E	2 1/2"	7/8" x 4 3/4"	5 1/2"	1" x 1"	2800	5500
18 1/2"	R16375	16.38"	11"	3.000"	93	148	2 1/2A	2 1/2"	7/8" x 4 3/4"	5 1/2"	1" x 1"	3300	6500
20"	R16375	16.38"	11"	3.000"	93	148	2 1/2M	2 1/2"	7/8" x 4 3/4"	5 1/2"	1" x 1"	3300	6500
24"	R2200	22.00"	11"	3.000"	100	N/A	3A	3"	7/8" x 4 3/4"	7"	1" x 2 1/2"	5000	N/A
26"	R2200	22.00"	11"	3.000"	100	N/A	3C	3"	7/8" x 4 3/4"	7"	1" x 2 1/2"	5000	N/A

Corporate

3701 Briarpark Dr • Ste 150
Houston, TX 77042
832.742.8500

Offshore/International and Manufacturing

1149 Smede Hwy
Broussard, LA 70518
337.856.0333

Product Sales

337.364.9244

Other Drilling Tools International Centers:

Houston, TX • 281.645.2010

Midland, TX • 432.563.0676

Odessa, TX • 432.248.8350

New Iberia, LA • 337.256.5848

Oklahoma City, OK • 405.604.2763

Bakersfield, CA • 661.869.1752

Casper, WY • 307.237.5248

Charleroi, PA • 724.565.5682

Williston, ND • 701.609.8702

Nisku, Alberta, Canada • 877.570.1962

ROLLER REAMERS ORDERING INFORMATION:

To order spare parts or to request quotes on complete reamer assemblies, please specify:

- Three- or six-point style
- String or nearbit application
- Roller cutter type
- Connections top and bottom
- Preferred fishing neck diameter and length
- Hole size
- Reamer inside diameter
- Bore for float

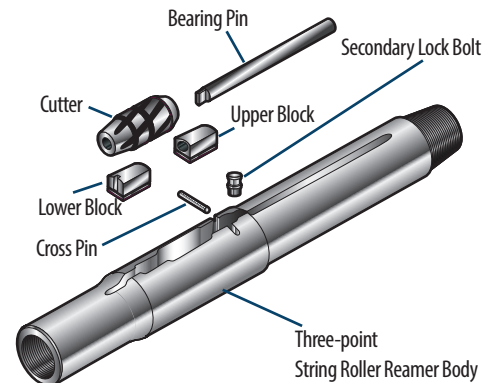

Drilling Tools International, Inc. is a leading provider of downhole tools to the land and offshore drilling markets. For nearly 40 years our company has been guided by the principals of Strength, Innovation and Performance. We consistently deliver world class customer service while providing quality products that meet the demanding drilling applications of today's market.

Our Quality Management System is certified in compliance to ISO 9001, and API Spec Q1 and our manufacturing is licensed to API Spec 7-1. Our Quality Management System governs all of our processes from planning, to process control, to delivery. This ensures that we consistently manufacture products that not only meet API standards but also meet the ever-changing needs of our customers.